

Product Summary

$V_{(BR)DSS}$	$R_{DS(on)TYP}$	I_D
100V	1.3m Ω @10V	350A

Feature

- Split Gate Trench Technology
- Low $R_{DS(on)}$
- Low Gate Charge
- Low Gate Resistance
- 100% UIS Tested

Application

- Power Management
- Motor Driving
- High frequency switching, synchronous rectification

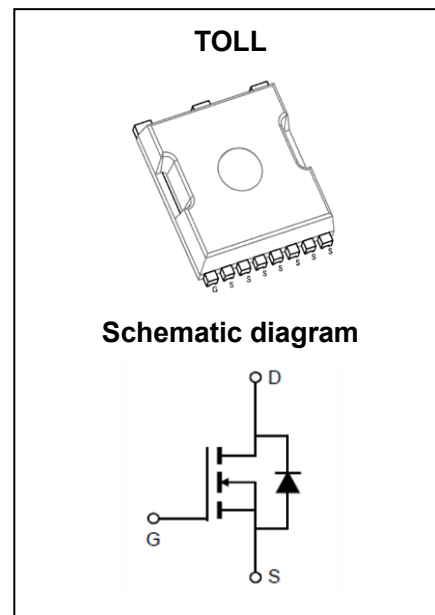
Package Marking and Ordering Information

Part Number	Package	Marking	Packing	Reel Size	Tape Width	Qty
GPT013N10NTPB	TOLL	T013N10NB	Reel & Tape	330mm	24mm	2000pcs

ABSOLUTE MAXIMUM RATINGS ($T_A = 25^\circ\text{C}$ unless otherwise noted)

Parameter	Symbol	Value	Unit
Drain-Source Voltage	V_{DS}	100	V
Gate-Source Voltage	V_{GS}	± 20	V
Continuous Drain Current ¹	I_D	$T_C = 25^\circ\text{C}$	350
		$T_C = 100^\circ\text{C}$	221
Pulsed Drain Current ²	I_{DM}	1400	A
Single Pulsed Avalanche Current ³	I_{AS}	90	A
Single Pulsed Avalanche Energy ³	E_{AS}	2025	mJ
Power Dissipation ⁵	P_D	$T_C = 25^\circ\text{C}$	329
Thermal Resistance from Junction to Ambient ⁶		$R_{\theta JA}$	30
Thermal Resistance from Junction to Case	$R_{\theta JC}$	0.38	$^\circ\text{C/W}$
Operating Junction and Storage Temperature Range	T_J, T_{STG}	-55~ +150	$^\circ\text{C}$

MOSFET ELECTRICAL CHARACTERISTICS ($T_A = 25^\circ\text{C}$ unless otherwise noted)

Parameter	Symbol	Test Condition	Min	Type	Max	Unit
Off Characteristics						
Drain-Source Breakdown Voltage	$V_{(BR)DSS}$	$V_{GS} = 0V, I_D = 250\mu A$	100			V
Zero Gate Voltage Drain Current	I_{DSS}	$V_{DS} = 100V, V_{GS} = 0V$			1	μA
Gate-Body Leakage Current	I_{GSS}	$V_{GS} = \pm 20V, V_{DS} = 0V$			± 100	nA
On Characteristics⁴						
Gate Threshold Voltage	$V_{GS(th)}$	$V_{DS} = V_{GS}, I_D = 250\mu A$	2.0	3.0	4.0	V
Drain-Source On-Resistance	$R_{DS(on)}$	$V_{GS} = 10V, I_D = 20A$		1.3	1.8	m Ω
Dynamic Characteristics						
Input Capacitance	C_{iss}	$V_{DS} = 50V, V_{GS} = 0V, f = 1MHz$		9427		pF
Output Capacitance	C_{oss}			3672		
Reverse Transfer Capacitance	C_{rss}			100		
Gate Resistance	R_g	$V_{DS} = 0V, V_{GS} = 0V, f = 1MHz$		3.1		Ω
Switching Characteristics						
Total Gate Charge	Q_g	$V_{DS} = 50V, V_{GS} = 10V, I_D = 20A$		143		nC
Gate-Source Charge	Q_{gs}			42		
Gate-Drain Charge	Q_{gd}			35		
Gate Plateau Voltage	$V_{plateau}$			4.6		V
Turn-On Delay Time	$t_{d(on)}$	$V_{DD} = 50V, V_{GS} = 10V, I_D = 80A, R_G = 3\Omega$		18		ns
Turn-On Rise Time	t_r			27		
Turn-Off Delay Time	$t_{d(off)}$			50		
Turn-Off Fall Time	t_f			30		
Source-Drain Diode Characteristics						
Diode Forward Voltage ⁴	V_{SD}	$V_{GS} = 0V, I_S = 20A$			1.2	V
Diode Continuous Forward Current ¹	I_S	$T_C = 25^\circ\text{C}$			350	A
Diode Pulse Forward Current ²	I_{SM}				1400	A
Diode Reverse Recovery Time	t_{rr}	$I_F = 80A, di/dt = 100A/\mu s$		78		ns
Diode Reverse Recovery Charge	Q_{rr}	$I_F = 80A, di/dt = 100A/\mu s$		150		nC

Notes:

1. The maximum current rating is limited by package. And device mounted on a large heatsink.
2. Pulse Test: Pulse Width $\leq 10\mu s$, duty cycle $\leq 1\%$.
3. EAS condition: $V_{DD} = 50V, V_{GS} = 10V, L = 0.5mH, R_G = 25\Omega$ Starting $T_J = 25^\circ\text{C}$.
4. Pulse Test: Pulse Width $\leq 300\mu s$, duty cycle $\leq 2\%$.
5. The power dissipation P_D is limited by $T_{J(MAX)} = 150^\circ\text{C}$. And device mounted on a large heatsink.
6. Device mounted on 1in² FR-4 board with 2oz. Copper, in a still air environment with $T_A = 25^\circ\text{C}$.

Typical Characteristics

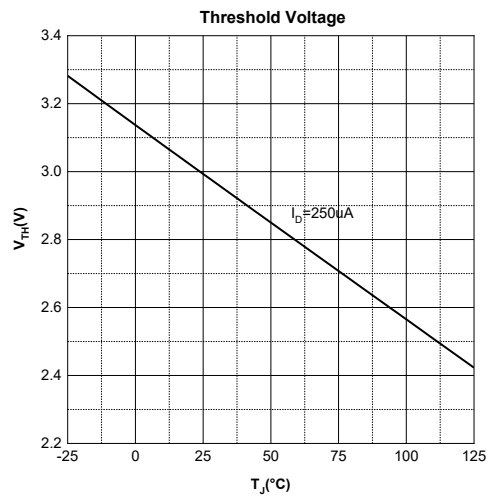
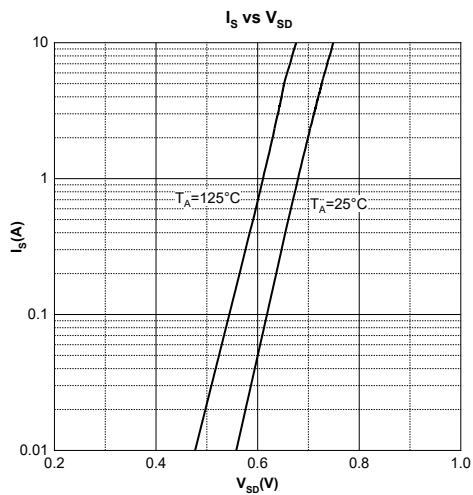
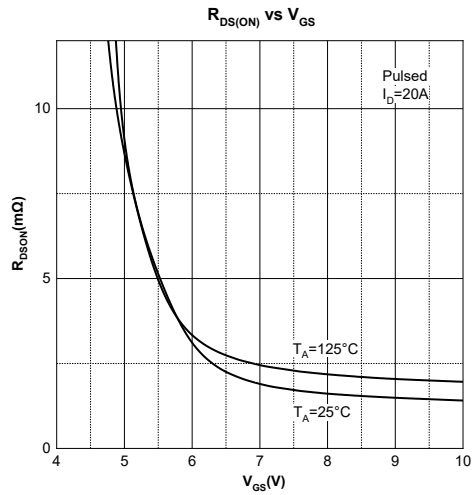
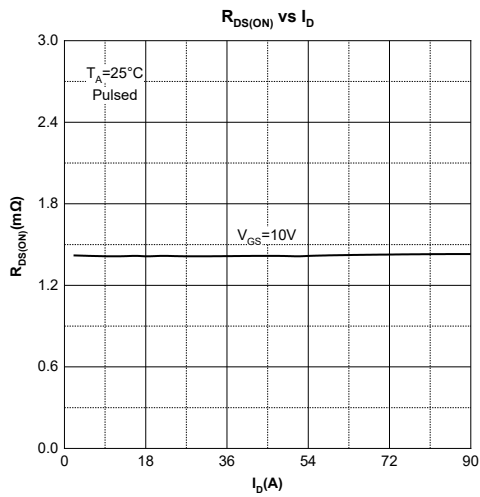
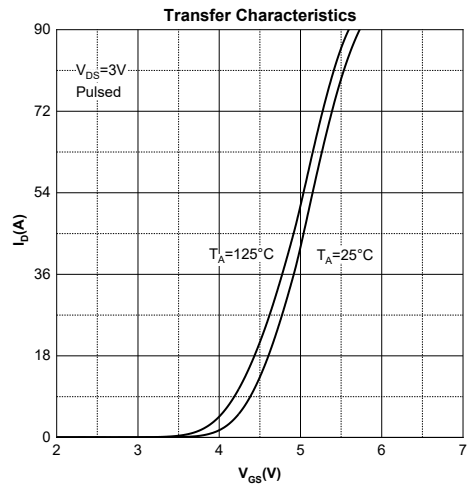
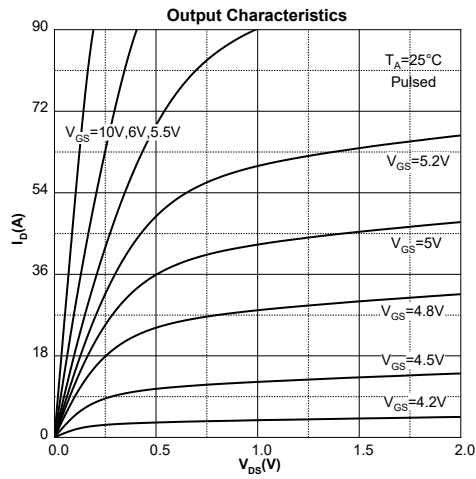

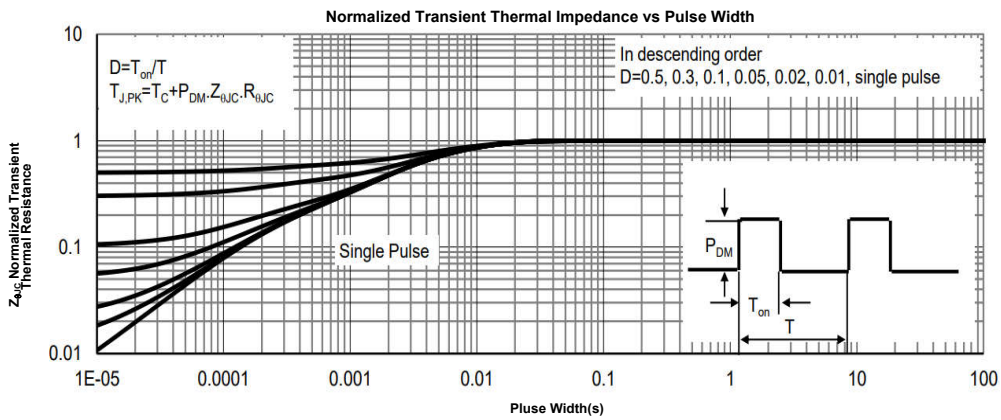
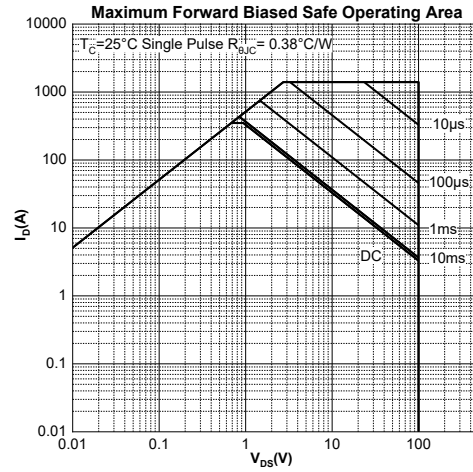
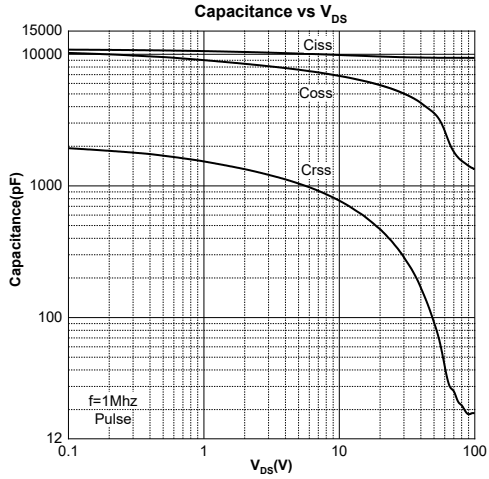

Test Circuit

Gate Charge Test Circuit & Waveform

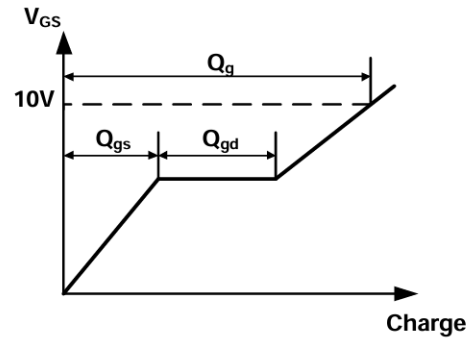
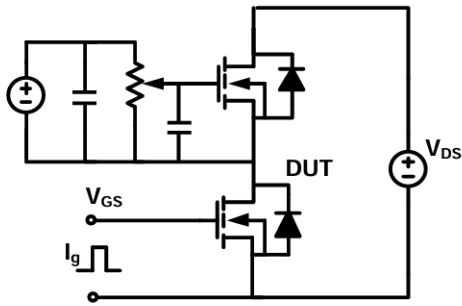

Resistive Switching Test Circuit & Waveform

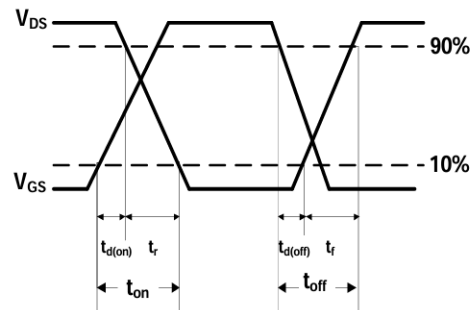
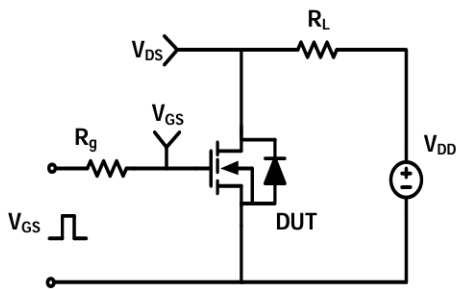

Unclamped Inductive Switching (UIS) Test Circuit & Waveform

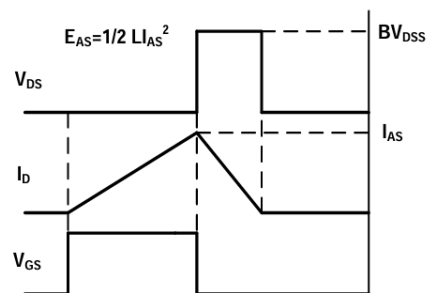
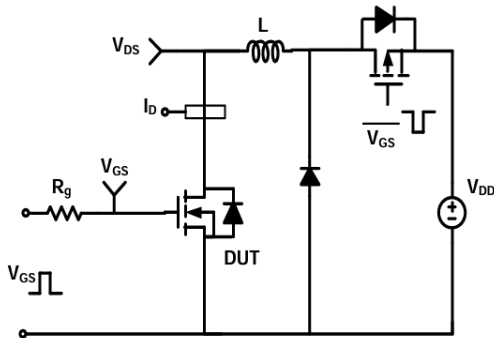

Diode Recovery Test Circuit & Waveform

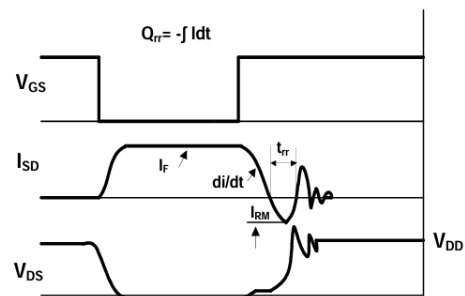
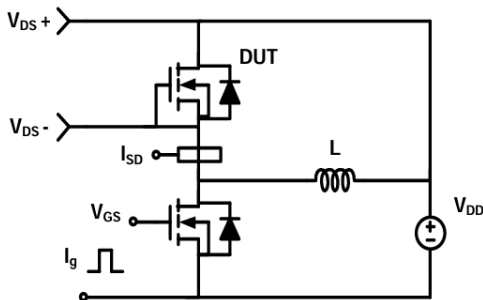

TOLL Package Information

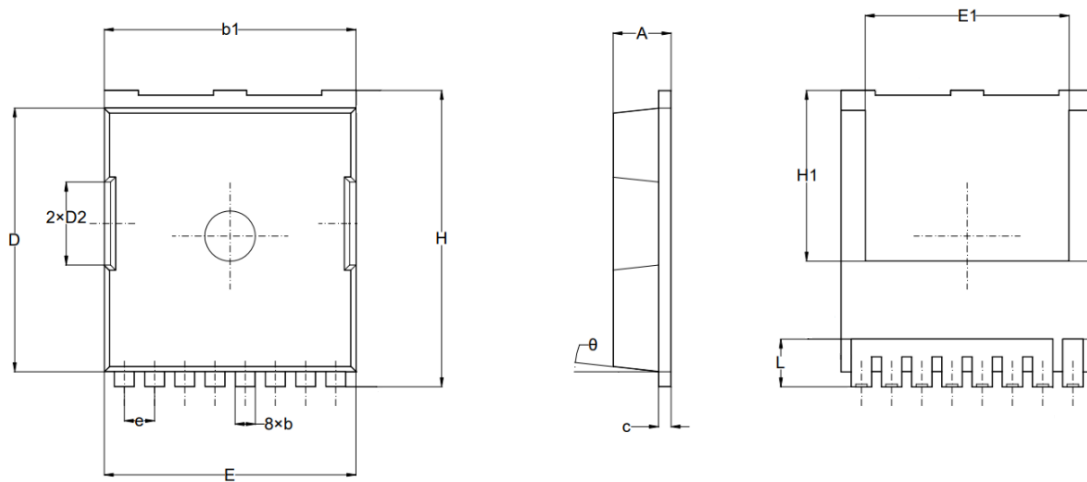

SYMBOL	MILLIMETER		Dimensions In Inches	
	MIN.	MAX.	Min.	Max.
A	2.150	2.450	0.085	0.096
b	0.600	0.900	0.024	0.035
b_1	9.650	10.000	0.380	0.394
c	0.400	0.600	0.016	0.024
D	10.180	10.580	0.401	0.417
D_2	2.850	3.450	0.112	0.136
E	9.700	10.100	0.382	0.398
E_1	7.900	9.250	0.311	0.364
e	1.100	1.300	0.043	0.051
H	11.000	11.900	0.433	0.469
H_1	6.750	7.350	0.266	0.289
L	1.270	2.100	0.050	0.083
θ	10°REF			

Attention:

- GreenPower Electronics reserves the right to improve product design function and reliability without notice.
- Any and all semiconductor products have certain probability to fail or malfunction, which may result in personal injury, death or property damage. Customer are solely responsible for providing adequate safe measures when design their systems.
- GreenPower Electronics products belong to consumer electronics or other civilian electronic products.